

Cross Bar Wind Noise

Service Category Vehicle Exterior

Section Exterior Panels/Trim

Market USA

Toyota Supports ASE Certification

Applicability

YEAR(S)	MODEL(S)	ADDITIONAL INFORMATION
2009 – 2010	Venza	

Introduction

2009 – 2010 model year Venza vehicles equipped with accessory roof rack and cross bar assemblies (P/N PT278-0T090) may exhibit a wind noise condition described as a whistling or howling. The noise can occur at low to high speeds.

Ensure the front and rear cross bar assemblies are installed correctly. The tip of the marking triangle should point toward the front of the vehicle.

Figure 1.

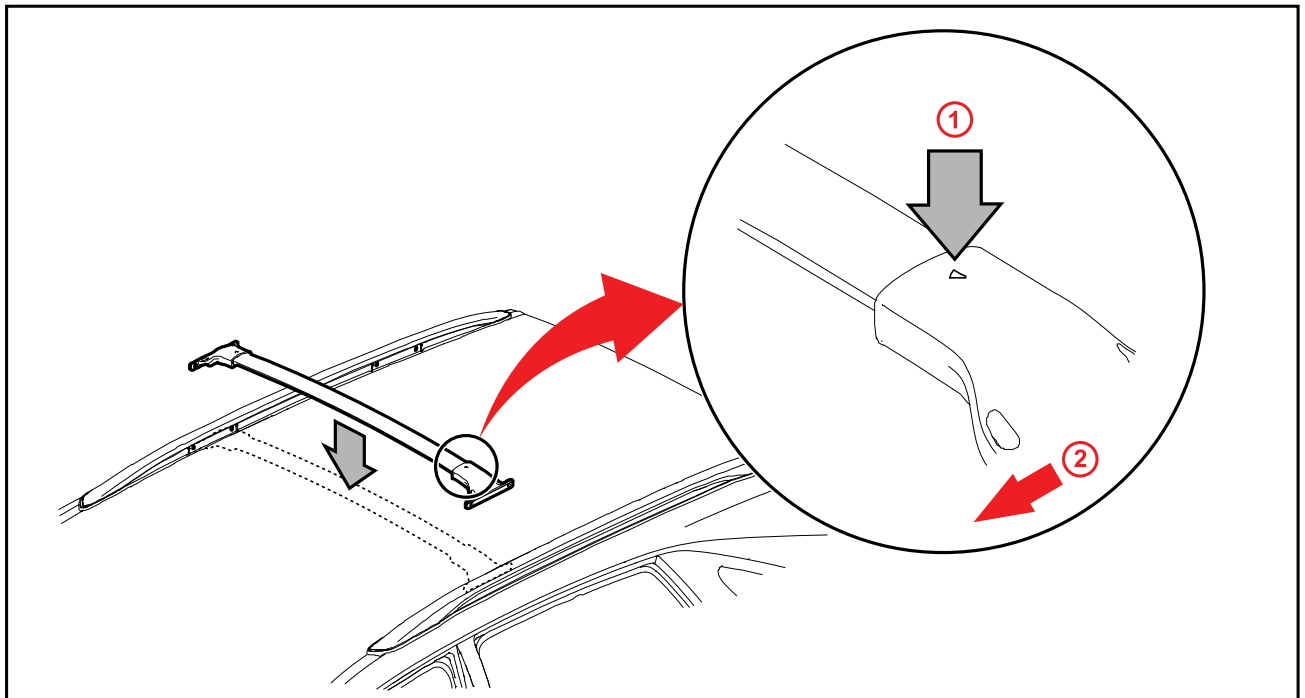

1 Triangle Direction Arrow

2 Front of Vehicle

Cross Bar Wind Noise

Introduction (Continued)

NOTE

For more information please refer to the [Roof Rails and Cross Bars](#) accessory installation instructions.

Warranty Information

OP CODE	DESCRIPTION	TIME	OFP	T1	T2
N/A	Not Applicable to Warranty	—	—	—	—

NOTE

This repair is not applicable to warranty. The roof rack/cross bar assembly is NOT a factory installed option — It is a customer or Dealer Installed Option (DIO) ONLY.